

2 - Hood/Tank

| CODE | DESCRIPTION |
|-------------|--------------------------------|
| 160811 | WASHER F2 18X8.5X1 ALGOF |
| 160907 | CONNECTION FOR TABLES C95-155 |
| 180642 | GUIDE |
| 190637 | GUIDE FOR DOOR "C" |
| 190638 | ROLLER FOR "C" DOOR GUIDE |
| 200925 | GASKET |
| 200957 | GASKET |
| 200964 | GASKET 618X14 SP.2 |
| 260113 | STAINL.ST.TE SCREW 8X20 A2 UNI |
| 260219 | STAINL.ST TCP SCREW 6X35 A2 UN |
| 260224 | TB-SCREW 6X15 B23-10-11-12 |
| 260329 | VITE M5X12 SPEC.ZIGR.SOTTOTEST |
| 260404 | STAINLESS STEEL NUTS D6 UNI 55 |
| 260504 | ST/ST FLAT WASHER D6 |
| 260505 | STAINL.STEEL FLAT WASHER D8 |
| 260512 | ST/ST GROWER WASHER D6 |
| 260513 | GROWER WASHER D8 |
| 260538 | WASHER 18X6X1,5 ST/ST |
| 260543 | WASHER D.6 ST/ST |
| 320534 | LOWER FRAME |
| 332424 | SQUADRETTA SOST.TUBO PRESS.C |
| 342258 | TANK |
| 342497 | HOOD |
| 342498 | INSULATED HOOD |
| 350796 | BRACKET F. RELAY SUPPORT S |
| 351421 | LEFT PANEL |
| 351422 | RIGHT PANEL |
| 351767 | FRONT PANEL |
| 351870 | FRONT PANEL LC2004 |
| 361069 | BACK FRAME |
| 390182 | BACK PANEL |
| 440211 | LEGS |
| 530238 | RACK SUPPORT C-SERIES |

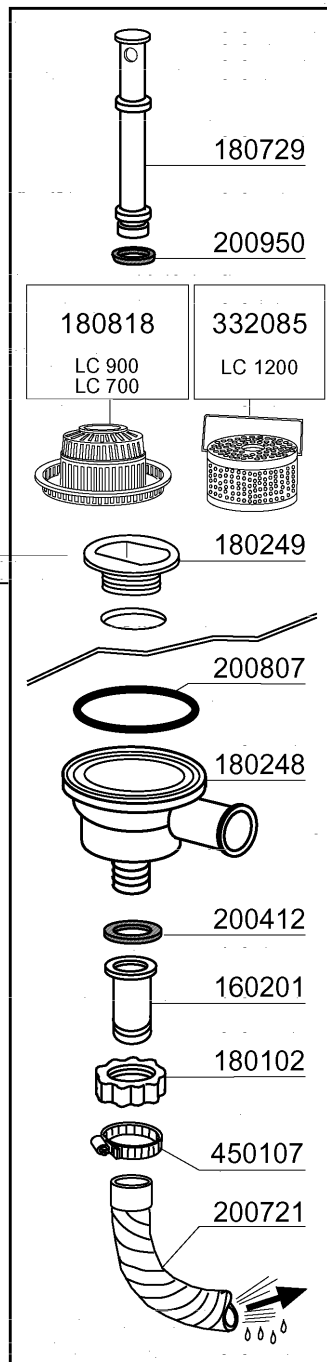
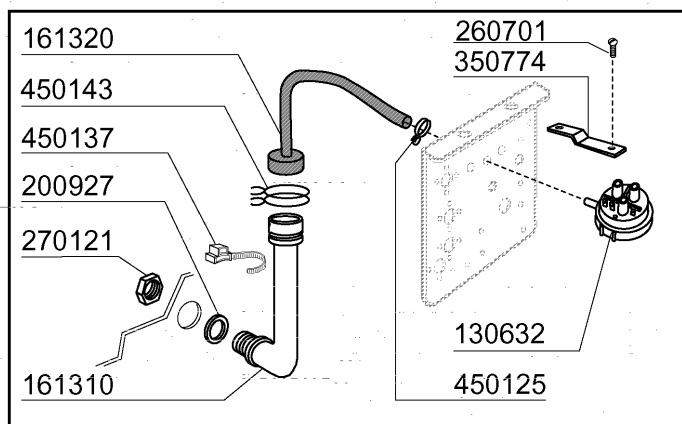
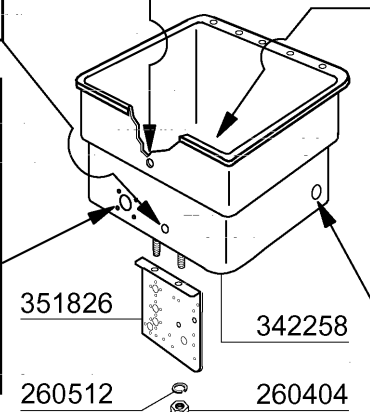
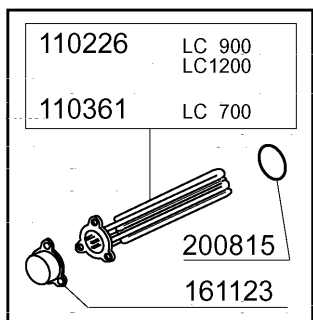
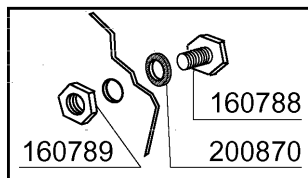
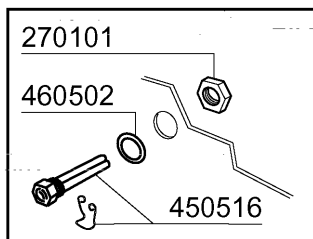
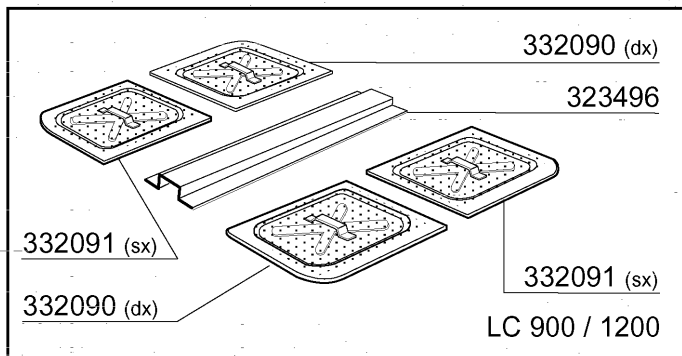

3 - Tank

| CODE | DESCRIPTION |
|-------------|--------------------------------|
| 110226 | HEAT. ELEMENT 3000W 230/400V |
| 110361 | HEAT. ELEMENT 2200W 230V |
| 130632 | PRESSURE SWITCH 1L |
| 160201 | ELBOW F.TANK INLET MOPLEN |
| 160788 | PLUG |
| 160789 | NUT |
| 161123 | HEAT.ELEMENT COVER H42 SNL |
| 161310 | AIR CHAMBER FOR GLASSWASHERS B |
| 161320 | HOSE FOR AIR CHAMBER |
| 180102 | DRAIN PIPE NUT 1"1/2 F45-55 |
| 180248 | SUCTION TANK |
| 180249 | NUT |
| 180729 | OVERFLOW PIPE |
| 180818 | STRAINER FOR FC |
| 200412 | GASKET DRAIN 11/2" 45X33X3 |
| 200721 | DRAIN HOSE 28X35 2MT. |
| 200807 | O-RING 3,53 X 110,72 |
| 200815 | O-RING F. HEAT.ELEM. |
| 200870 | GASKET 18X10X2 |
| 200927 | GASKET FOR AIR TRAP |
| 200950 | VITON GASKET |
| 260404 | STAINLESS STEEL NUTS D6 UNI 55 |
| 260512 | ST/ST GROWER WASHER D6 |
| 260701 | SCREW 3,5X9,5 |
| 270101 | HEXAGON LOCK NUT 1/2" |
| 270121 | NUT FOR AIR TRAP |
| 323496 | STRAINERS SUPPORT |
| 332085 | STRAINER LC |
| 332090 | RIGHT STRAINER |
| 332091 | TANK LEFT STRAINER |
| 342258 | TANK |
| 350774 | BRACKET |
| 351826 | BRACKET |
| 450107 | CLAMP FE ZN 38-50 H=12,2 |
| 450125 | ELASTIC CLAMP D. 10,4X9,8 |
| 450137 | COLLAR CONNECTION WITH BASE 31 |
| 450143 | CLAMP D.39,7 X 37,7 |
| 450516 | THERMOSTAT SHIELD FOR 2 TERMOS |
| 460502 | GASKET 30X21X2 |

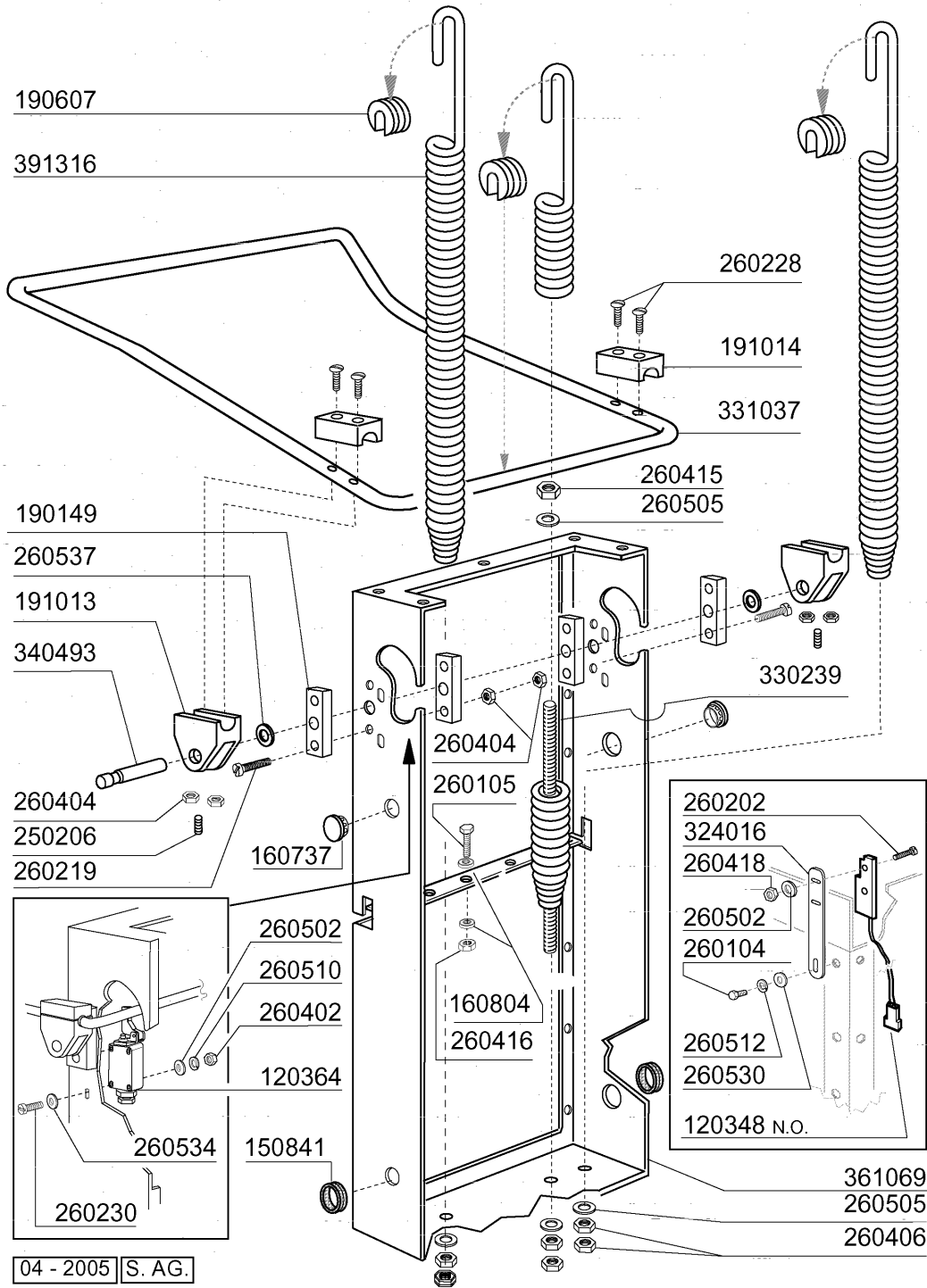

4 - Handle

| CODE | DESCRIPTION |
|--------|--------------------------------|
| 120348 | MAGN.SWITCH (N.O.) |
| 120364 | LIMIT SWITCH WITH LEVER |
| 150841 | CABLE HOLDER |
| 160737 | PLUG HEYCO D.34,9 |
| 160804 | GASKET D.6 |
| 190149 | REINFORCEMENT FOR HANDLE SUPP. |
| 190607 | HANDLE BUSH C30-70 |
| 191013 | HINGE F. SUPPORT C30-C70 |
| 191014 | FLANGE F. HANDLE C30-70 |
| 250206 | GRUB SCREW D.6 |
| 260104 | STAINL.ST TE-SCREW A2 6X16 UNI |
| 260105 | SCREW TE 6X20 |
| 260202 | SCREW TCP 3X16 |
| 260219 | STAINL.ST TCP SCREW 6X35 A2 UN |
| 260228 | STAINL.ST SPECIAL SCREW 6X42 3 |
| 260230 | SCREW TCP 4X40 |
| 260402 | STAINLESS STEEL NUT D4 UNI 55 |
| 260404 | STAINLESS STEEL NUTS D6 UNI 55 |
| 260406 | NUT 8MA |
| 260415 | STAINLESS STEEL SELF-LOCKING N |
| 260416 | STAINLESS STEEL NUTS M6 |
| 260418 | SELF-LOCKING NUT M4 |
| 260502 | S/S FLAT WASHER D.4 |
| 260505 | STAINL.STEEL FLAT WASHER D8 |
| 260510 | GROWER WASHER D.4 |
| 260512 | ST/ST GROWER WASHER D6 |
| 260530 | STAINL.ST WASHER 7X22X2 |
| 260534 | WASHER |
| 260537 | STAINL.STEEL FLAT WASHER D13X2 |
| 324016 | SWITCH BRACKET |
| 330239 | ROD |
| 331037 | HANDLE C95-155-165 ISOLATED |
| 340493 | PIN F. HINGE C30 |
| 361069 | BACK FRAME |
| 391316 | SPRING FOR HANDLE C85/140-G75 |

5 - Wash/Rinse column

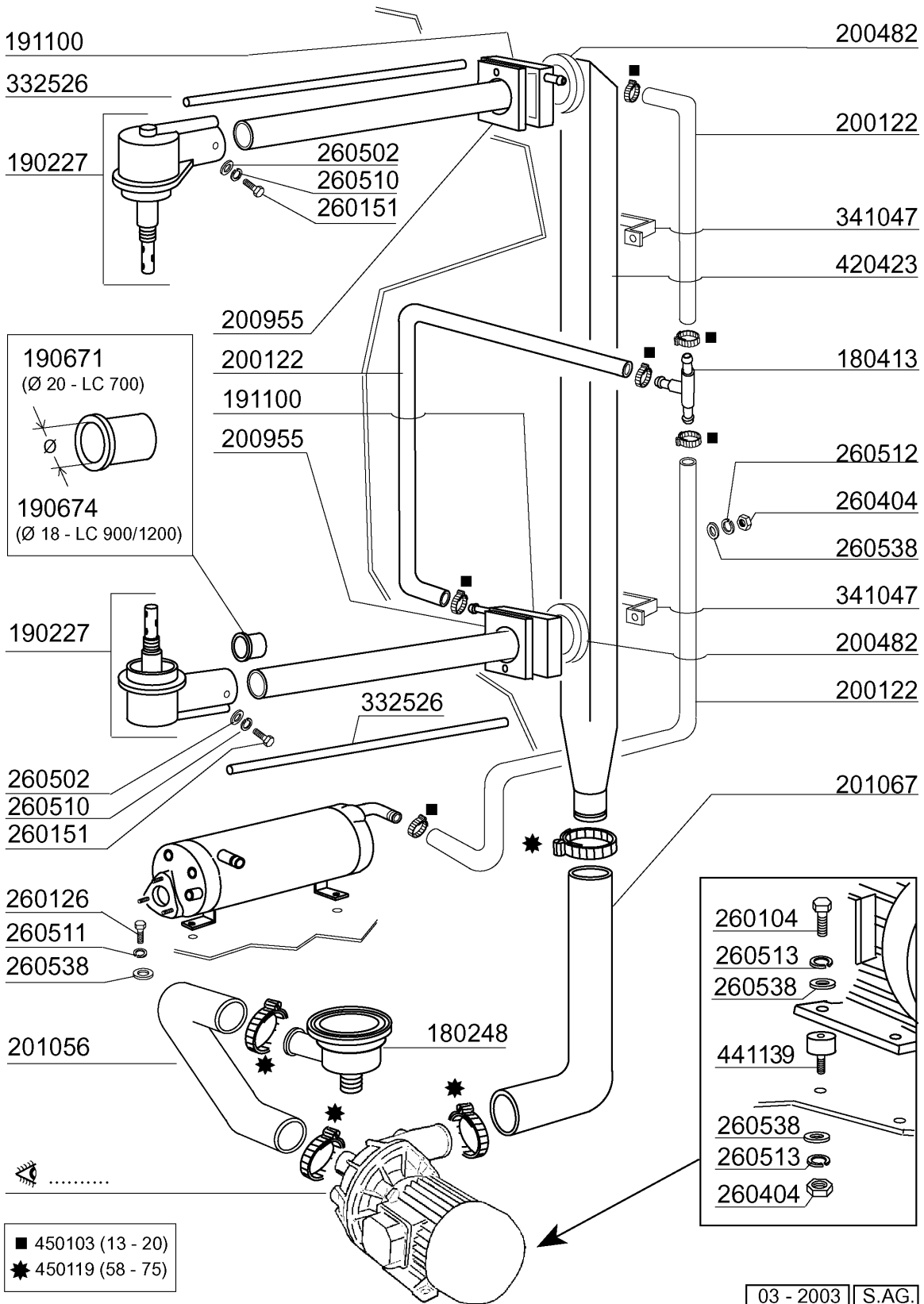

5 - Wash/Rinse column

| CODE | DESCRIPTION |
|--------|--------------------------------|
| 180248 | SUCTION TANK |
| 180413 | TEE NIPPLE D.11,5 - RINSE ASSE |
| 190227 | ARM SUPPORT |
| 190671 | BUSH |
| 190674 | BUSH |
| 191100 | RINSE COLLECTOR C-LC |
| 200122 | HOSE 11X19 |
| 200482 | GASKET 60X54 RAMP C140 |
| 200955 | GASKET |
| 201056 | WASH PUMP INLET HOSE |
| 201067 | OUTLET HOSE |
| 260104 | STAINL.ST TE-SCREW A2 6X16 UNI |
| 260126 | SCREW TE 5X12 |
| 260151 | SCREW TE 4X12 |
| 260404 | STAINLESS STEEL NUTS D6 UNI 55 |
| 260502 | S/S FLAT WASHER D.4 |
| 260510 | GROWER WASHER D.4 |
| 260511 | GROWER WASHER D.5 |
| 260512 | ST/ST GROWER WASHER D6 |
| 260513 | GROWER WASHER D8 |
| 260538 | WASHER 18X6X1,5 ST/ST |
| 332526 | RINSE HOSE |
| 341047 | U-BOLT FOR WASH.RAMP |
| 420423 | WASH RAMP C/LC |
| 441139 | VIBRATION-DAMPING FEET 25X20X6 |
| 450103 | CLAMP FE ZN. 13-20 H=9 |
| 450119 | CLAMP FE ZN. 58-75 H=12,2 |

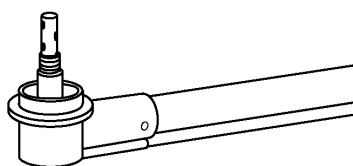
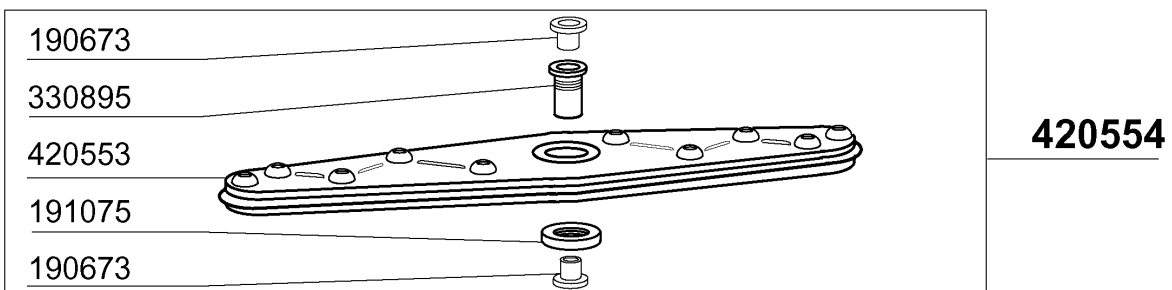
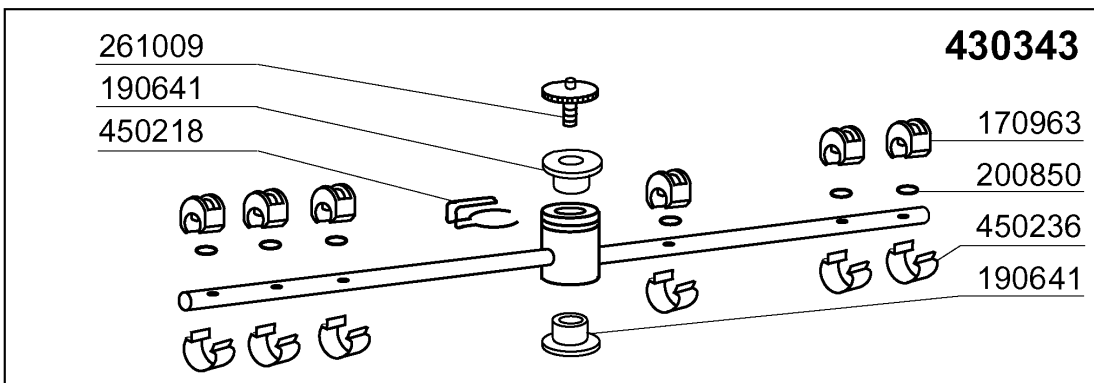
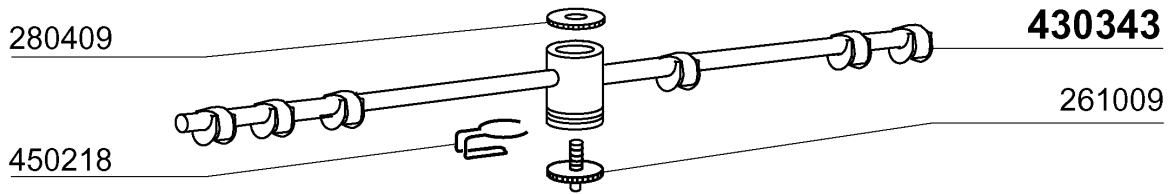
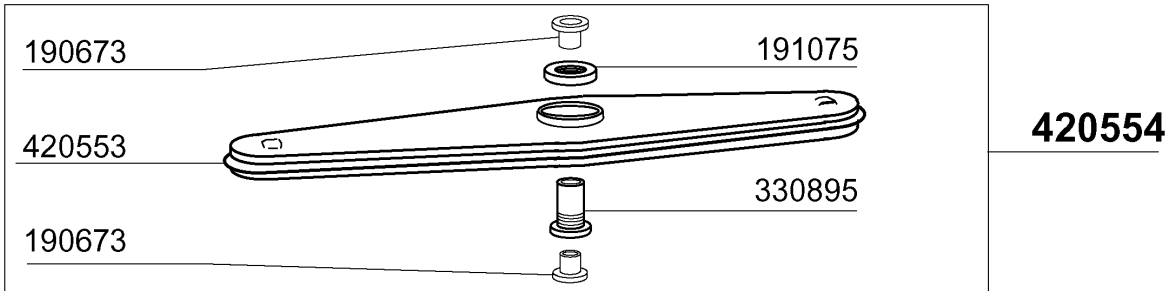
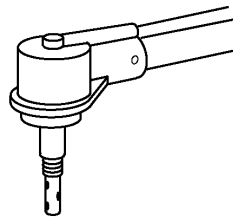

6 - Wash arm

| CODE | DESCRIPTION |
|-------------|--------------------------------|
| 170963 | RINSE JET X FC |
| 190641 | BUSH FOR C95-155-165 RINSE ARM |
| 190663 | BUSH |
| 190673 | BUSH |
| 191075 | RETAIN.LOCK |
| 200850 | O-RING |
| 261009 | RETAIN.SCREW FOR WASH-RINSE AR |
| 280409 | RETAIN.LOCK NUT CENTR.CROSS C1 |
| 330895 | WASH ARM CENTER |
| 420553 | S/STEEL WASH ARM - 420572R |
| 420554 | WASH ARM (420572R) |
| 430343 | RINSE ARM LC700/900/1200 |
| 450218 | SPRING F.RINSE ARM RETAIN.SCRE |
| 450236 | SPRING FOR WASHER 170963 |

* dalla matricola
a partir de la matr.
from serial no.
ab Seriennr.
despues la matr.
01 - 2003

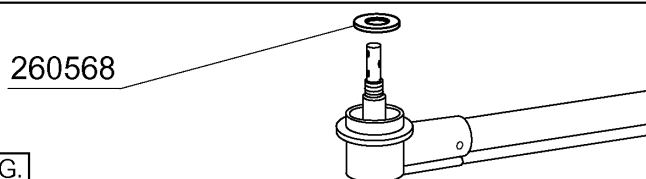
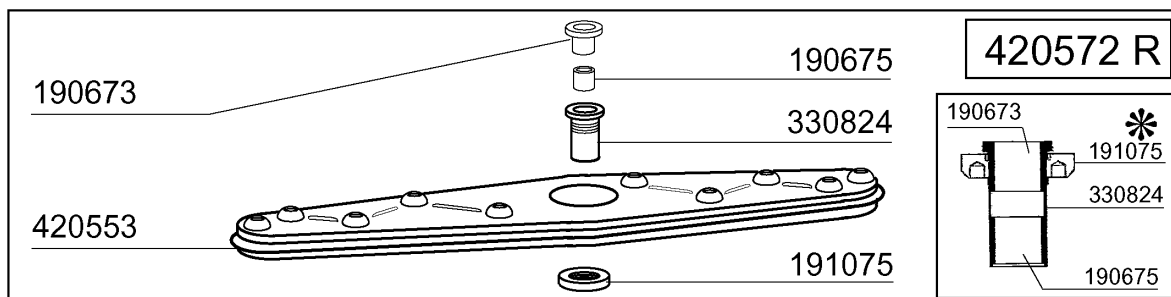
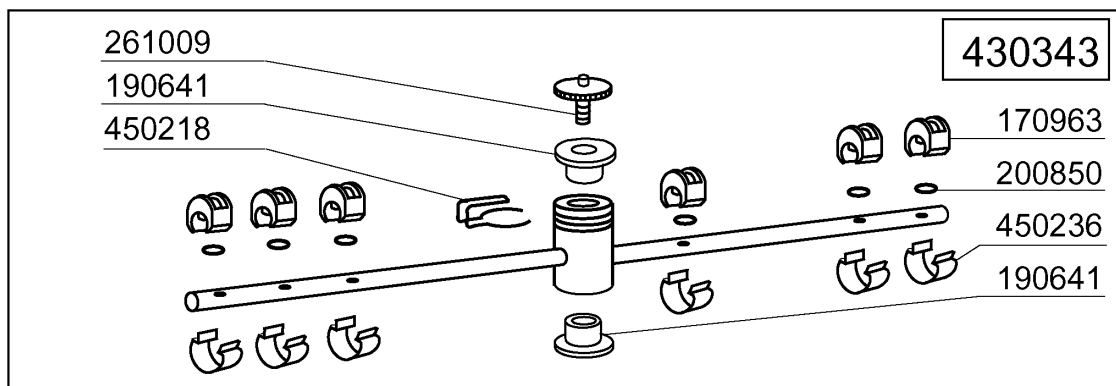
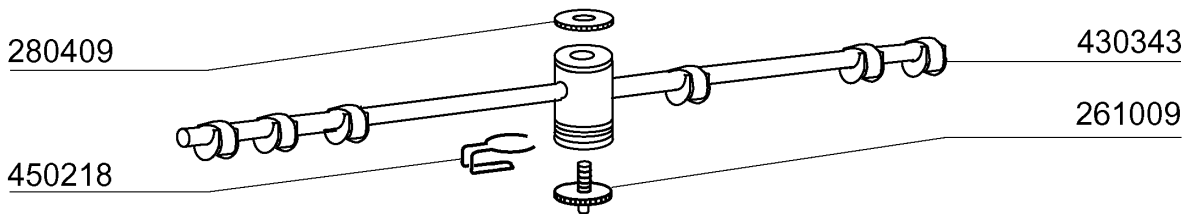
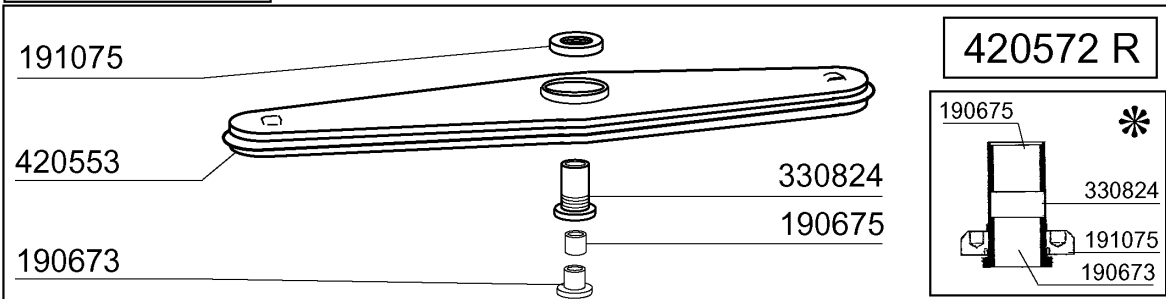
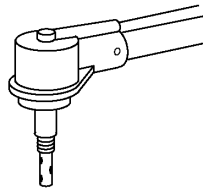

07 - 2003 S.A.G.

7 - Wash arm

| CODE | DESCRIPTION |
|---------|--------------------------------|
| 170963 | RINSE JET X FC |
| 190641 | BUSH FOR C95-155-165 RINSE ARM |
| 190673 | BUSH |
| 190675 | BUSH |
| 191075 | RETAIN.LOCK |
| 200850 | O-RING |
| 260568 | S/S FLAT WASHER D.28X21X1 |
| 261009 | RETAIN.SCREW FOR WASH-RINSE AR |
| 280409 | RETAIN.LOCK NUT CENTR.CROSS C1 |
| 330824 | WASH ARM CENTER (STAINL.) |
| 420553 | S/STEEL WASH ARM - 420572R |
| 420572R | WASH ARM LC |
| 430343 | RINSE ARM LC700/900/1200 |
| 450218 | SPRING F.RINSE ARM RETAIN.SCRE |
| 450236 | SPRING FOR WASHER 170963 |

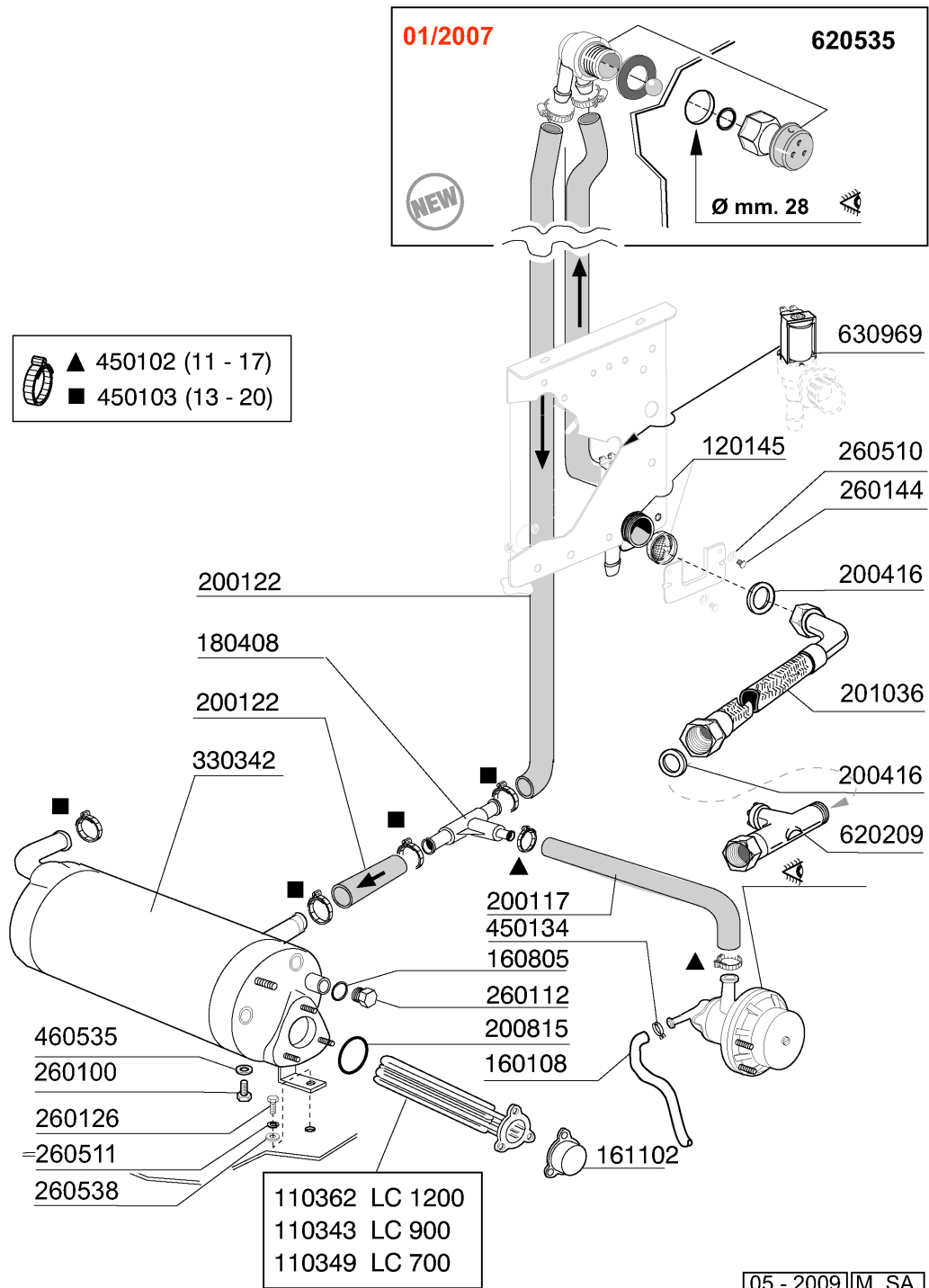

8 - Rinse assembly

| CODE | DESCRIPTION |
|--------|--------------------------------|
| 110343 | HEAT.ELEM. 8000W 220/380V |
| 110349 | HEAT.ELEMENT 6000W 230/400V |
| 110362 | HEAT.ELEMENT 9000W 220/380V |
| 120145 | SOLENOID VALVE 12 LT 1 WAY |
| 160108 | INJECT.INLET HOSE D.8X5 |
| 160805 | GASKET D.8 |
| 161102 | ELEMENT COVER MOPL. |
| 180408 | TEE-NIPPLE F.INJECT.W/CENTR.RE |
| 200117 | RUBBER HOSE 7X16 |
| 200122 | HOSE 11X19 |
| 200416 | GASKET D. 3/4" |
| 200815 | O-RING F. HEAT.ELEM. |
| 201036 | INLET HOSE 2 MT |
| 260100 | SCREW TE 6X8 INOX |
| 260112 | STAINLESS STEEL TE-SCREW 8X16 |
| 260126 | SCREW TE 5X12 |
| 260144 | SCREW TE 4X6 |
| 260510 | GROWER WASHER D.4 |
| 260511 | GROWER WASHER D.5 |
| 260538 | WASHER 18X6X1,5 ST/ST |
| 330342 | BOILER C95-C155-C165 |
| 450102 | CLAMP FE ZN 11-17 H=9 |
| 450103 | CLAMP FE ZN. 13-20 H=9 |
| 450134 | ELASTIC HOSE CLIP D.9,3/8,8 |
| 460535 | GASKET FOR BOILER PLUG BHC |
| 620209 | INLET WATER FILTER |
| 620535 | VACUUM BREAKER |
| 630969 | COIL S4216 220/50HZ |

9 - Thermostat/solenoid valve group

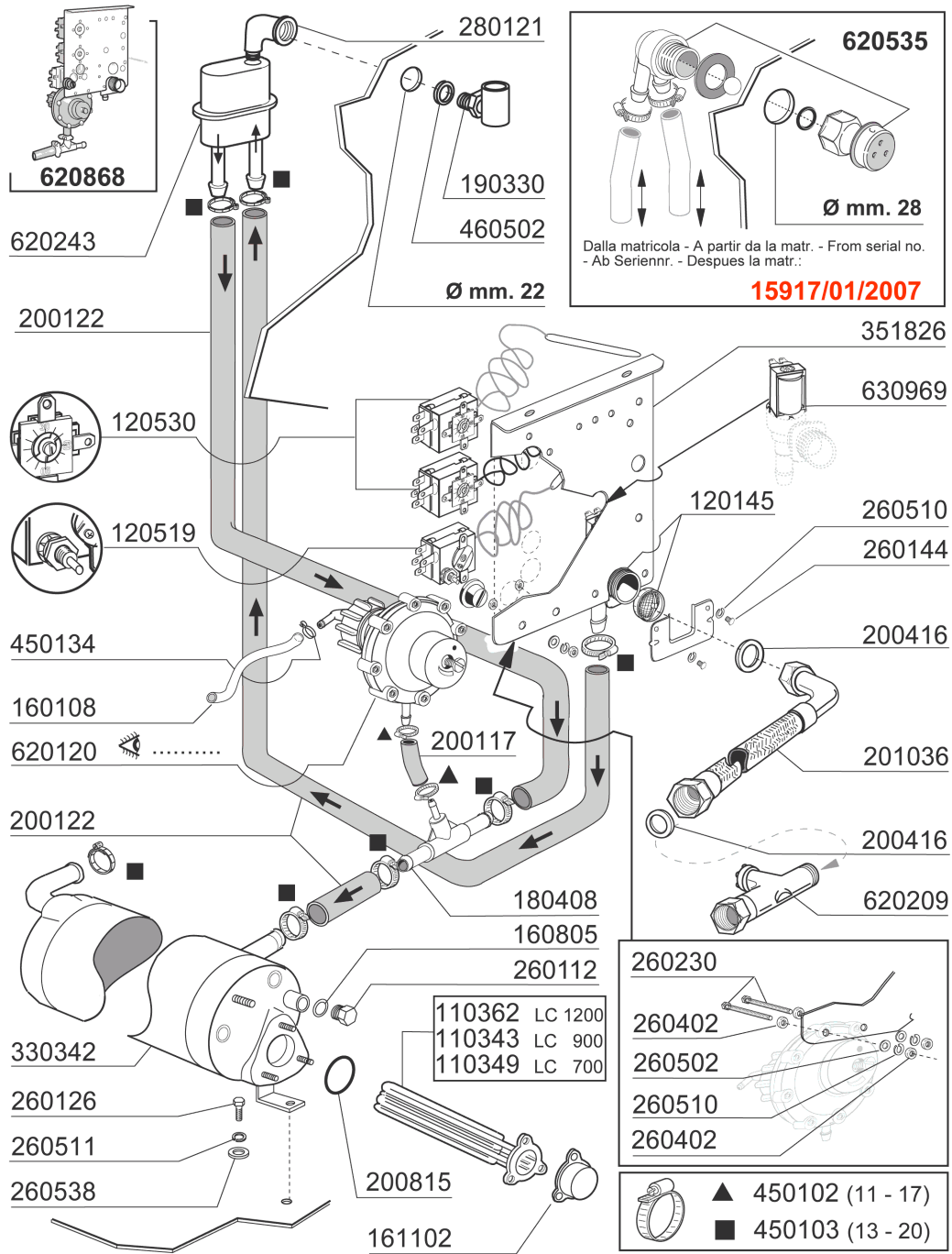

02 - 2007 | S. AG.

9 - Thermostat/solenoid valve group

| CODE | DESCRIPTION |
|--------|--------------------------------|
| 110343 | HEAT.ELEM. 8000W 220/380V |
| 110349 | HEAT.ELEMENT 6000W 230/400V |
| 110362 | HEAT.ELEMENT 9000W 220/380V |
| 120145 | SOLENOID VALVE 12 LT 1 WAY |
| 120519 | SECURITY THERMOSTAT 95-125Ø |
| 120530 | THERMOSTAT 0-90Ø |
| 160108 | INJECT.INLET HOSE D.8X5 |
| 160805 | GASKET D.8 |
| 161102 | ELEMENT COVER MOPL. |
| 180408 | TEE-NIPPLE F.INJECT.W/CENTR.RE |
| 190330 | TEE FOR VAACUM BREAKER |
| 200117 | RUBBER HOSE 7X16 |
| 200122 | HOSE 11X19 |
| 200416 | GASKET D. 3/4" |
| 200815 | O-RING F. HEAT.ELEM. |
| 201036 | INLET HOSE 2 MT |
| 260112 | STAINLESS STEEL TE-SCREW 8X16 |
| 260126 | SCREW TE 5X12 |
| 260144 | SCREW TE 4X6 |
| 260230 | SCREW TCP 4X40 |
| 260402 | STAINLESS STEEL NUT D4 UNI 55 |
| 260502 | S/S FLAT WASHER D.4 |
| 260510 | GROWER WASHER D.4 |
| 260511 | GROWER WASHER D.5 |
| 260538 | WASHER 18X6X1,5 ST/ST |
| 280121 | ELL FOR VAACUM BREAKER |
| 330342 | BOILER C95-C155-C165 |
| 351826 | BRACKET |
| 450102 | CLAMP FE ZN 11-17 H=9 |
| 450103 | CLAMP FE ZN. 13-20 H=9 |
| 450134 | ELASTIC HOSE CLIP D.9,3/8,8 |
| 460502 | GASKET 30X21X2 |
| 620120 | RINSE AID INJECTOR |
| 620209 | INLET WATER FILTER |
| 620243 | VACUUM BREAKER (WITHOUT KIT) |
| 620535 | VACUUM BREAKER |
| 620868 | -ASSIEME COMPONENTI LC |
| 630969 | COIL S4216 220/50HZ |

10 - Thermostat/solenoid valve group

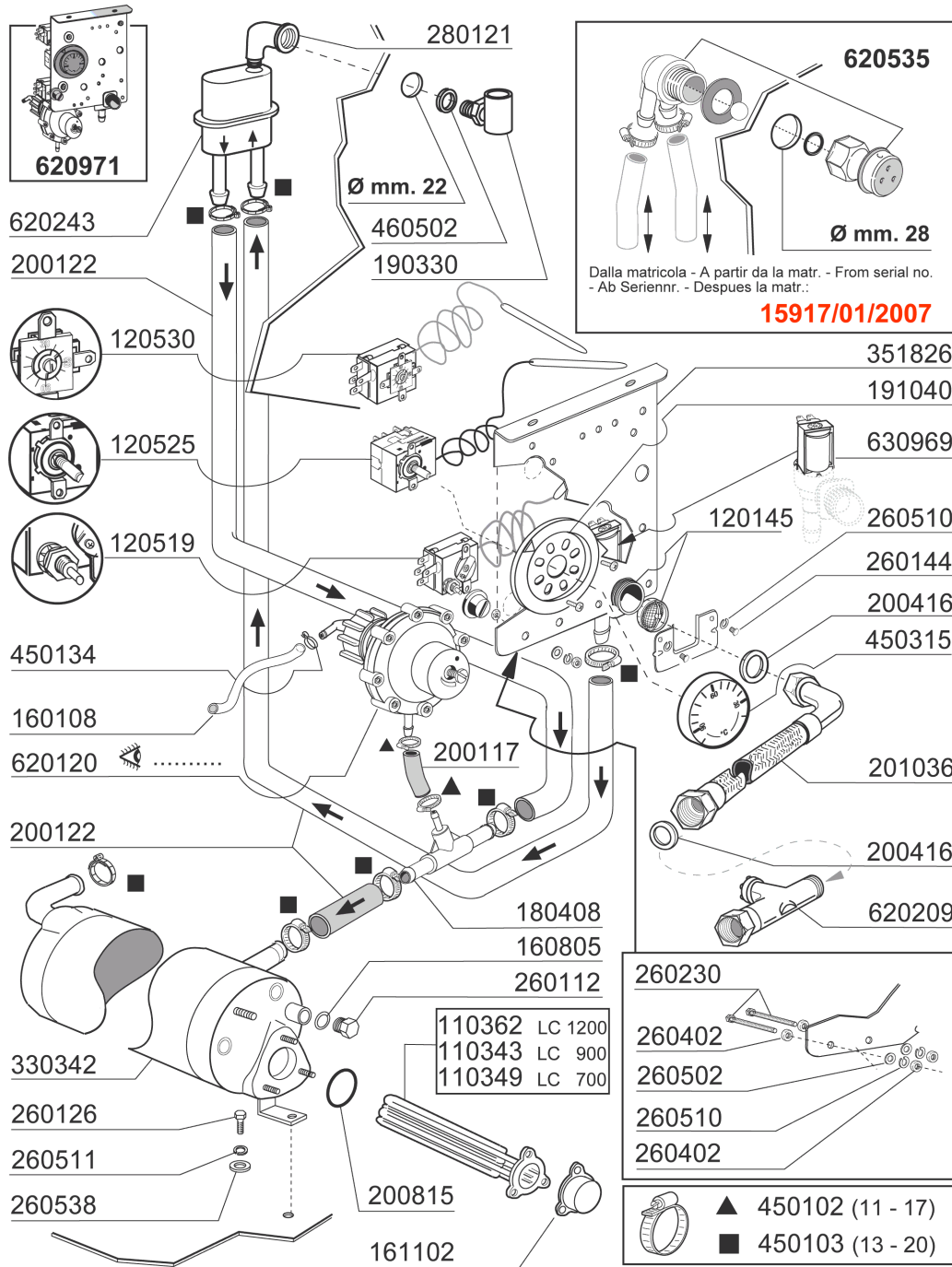

02 - 2007 | S. AG.

10 - Thermostat/solenoid valve group

| CODE | DESCRIPTION |
|--------|--------------------------------|
| 110343 | HEAT.ELEM. 8000W 220/380V |
| 110349 | HEAT.ELEMENT 6000W 230/400V |
| 110362 | HEAT.ELEMENT 9000W 220/380V |
| 120145 | SOLENOID VALVE 12 LT 1 WAY |
| 120519 | SECURITY THERMOSTAT 95-125Ø |
| 120525 | BOOSTER THERMOSTAT 2 TEMPERAT. |
| 120530 | THERMOSTAT 0-90Ø |
| 160108 | INJECT.INLET HOSE D.8X5 |
| 160805 | GASKET D.8 |
| 161102 | ELEMENT COVER MOPL. |
| 180408 | TEE-NIPPLE F.INJECT.W/CENTR.RE |
| 190330 | TEE FOR VAACUM BREAKER |
| 191040 | FRAME F.THERMOSTAT KNOB |
| 200117 | RUBBER HOSE 7X16 |
| 200122 | HOSE 11X19 |
| 200416 | GASKET D. 3/4" |
| 200815 | O-RING F. HEAT.ELEM. |
| 201036 | INLET HOSE 2 MT |
| 260112 | STAINLESS STEEL TE-SCREW 8X16 |
| 260126 | SCREW TE 5X12 |
| 260144 | SCREW TE 4X6 |
| 260230 | SCREW TCP 4X40 |
| 260402 | STAINLESS STEEL NUT D4 UNI 55 |
| 260502 | S/S FLAT WASHER D.4 |
| 260510 | GROWER WASHER D.4 |
| 260511 | GROWER WASHER D.5 |
| 260538 | WASHER 18X6X1,5 ST/ST |
| 280121 | ELL FOR VAACUM BREAKER |
| 330342 | BOILER C95-C155-C165 |
| 351826 | BRACKET |
| 450102 | CLAMP FE ZN 11-17 H=9 |
| 450103 | CLAMP FE ZN. 13-20 H=9 |
| 450134 | ELASTIC HOSE CLIP D.9,3/8,8 |
| 450315 | KNOB F. THERMOSTAT 90Ø |
| 460502 | GASKET 30X21X2 |
| 620120 | RINSE AID INJECTOR |
| 620209 | INLET WATER FILTER |
| 620243 | VACUUM BREAKER (WITHOUT KIT) |
| 620535 | VACUUM BREAKER |
| 620971 | -ASSIEME COMPONENTI LC 2004 |
| 630969 | COIL S4216 220/50HZ |

630330
 630252
 630411
 630501
 632501 50 HZ
 632502 60 HZ

630254

631202
 16 µF

LC 700

100801
 220/240 V
 50 Hz - HP 1
 Kw 0,75 (5223)

630306
 630252
 630411
 630501
 631653 50 HZ
 631654 60 HZ

630253

LC 900

100797
 230/400 V
 50Hz - HP 1.5
 Kw 1,1 (5233)

630306
 630252
 630411
 630501
 631618 50 HZ
 631647 60 HZ

630253

LC 1200

100795
 230/400 V
 50 Hz - HP 2
 Kw 1,5 (5234)

11 - Wash pump

| CODE | DESCRIPTION |
|--------|--------------------------------|
| 100795 | PUMP 2HP 380/3/50HZ |
| 100797 | PUMP HP 1,5 380/3/50 |
| 100801 | PUMP 1HP 230/1 |
| 630138 | VOLUTE FOR PUMP LC |
| 630252 | BACK PLATE PUMP LC |
| 630253 | FAN HOUSING FOR PUMP 100797 |
| 630254 | FAN HOUSING FOR PUMP 100801 |
| 630306 | PUMP FAN IMPELLOR FI HP.2-3 |
| 630330 | PUMP 100801 FAN IMPELLOR |
| 630411 | O-RING PUMP FI HP 2-2,7 |
| 630501 | SEAL FOR PUMP HP 2-3-3,2 |
| 631202 | CONDENSER 16 MF 450V |
| 631618 | IMPELLER PUMP F HP2-D.116,5 |
| 631647 | IMPELLER D.100-60HZ-1204/5 |
| 631653 | PUMP IMPELLER 1,5 HP 50HZ 1241 |
| 631654 | PUMP IMPELLER 1,5HP 50HZ 1241 |
| 632501 | PUMP IMPELLER 1HP 50HZ-5223 |
| 632502 | PUMP IMPELLER 1HP 60HZ-5223 |

463163 (LC 700)
 463164 (LC 900)
 463165 (LC 1200)

112833

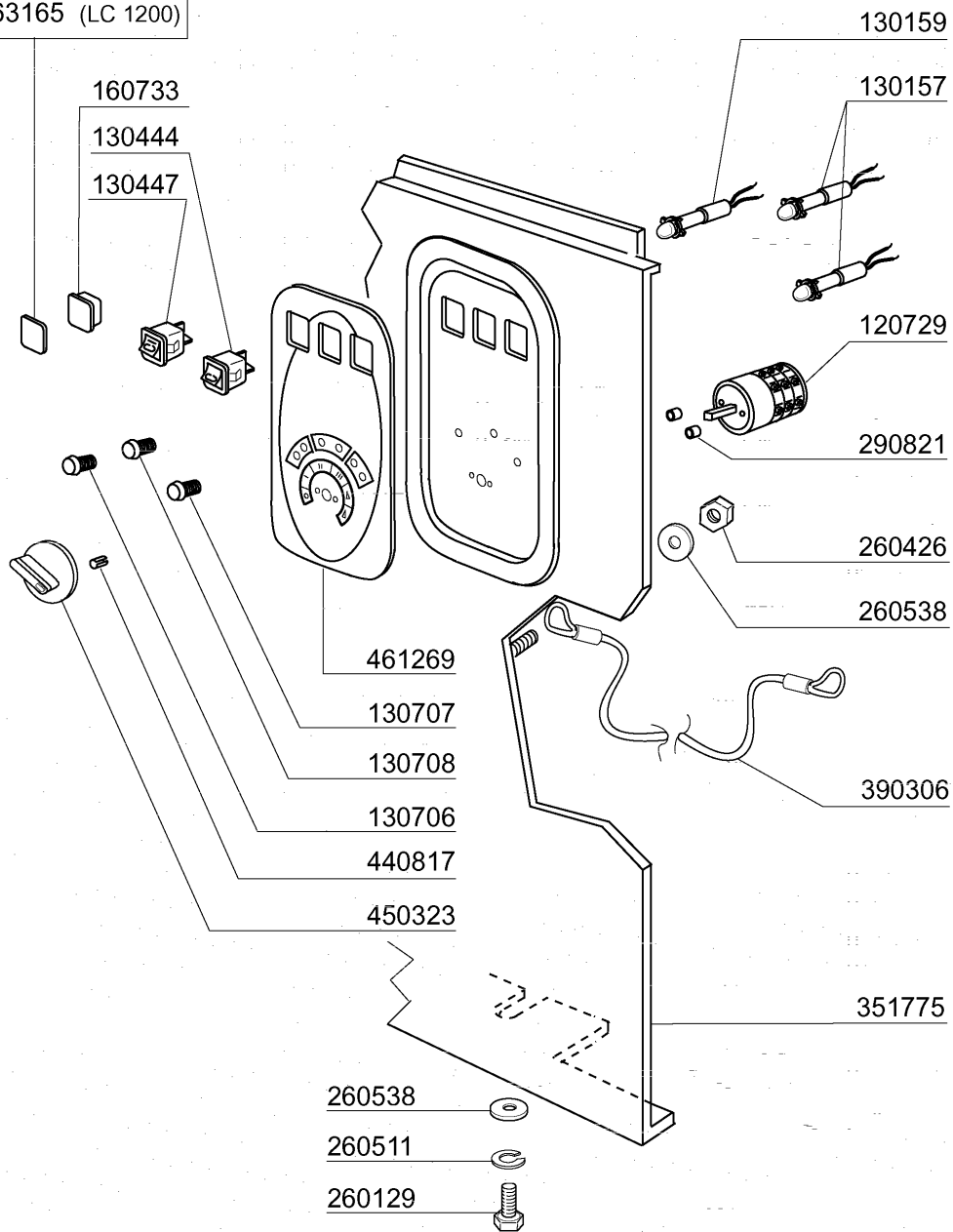

05 - 2004 | S. AG.

12 - Control panel

| CODE | DESCRIPTION |
|--------|--------------------------------|
| 112833 | CONTROL PANEL |
| 120729 | EIGHT-POLE SWITCH 16A 5 POS. |
| 130157 | GREEN LED FOR BR-BC-C-SERIES - |
| 130159 | ORANGE LED FOR C-SERIES - 220V |
| 130444 | SWITCH "START CYCLE" F |
| 130447 | CYCLE START SELECTOR FOR C-SER |
| 130706 | ORANGE LENS COVERS (C-SERIES) |
| 130707 | TRANSPARENT LENS COVERS (C-SER |
| 130708 | GREEN LENS COVERS (C-SERIES) |
| 160733 | BLANK PLATES |
| 260129 | SCREW TE M 5X20 |
| 260426 | DADI ESAG.CIECHI INOX "M6" |
| 260511 | GROWER WASHER D.5 |
| 260538 | WASHER 18X6X1,5 ST/ST |
| 290821 | DISTANCE PIECE FOR SWITCH |
| 351775 | FRONT PANEL |
| 390306 | CABLE |
| 440817 | SNAP RING LSCB/1853/17/00 |
| 450323 | KNOB FOR BC-BR-C95-C155 |
| 461269 | PLATE LC |
| 463163 | LC700 PLATE |
| 463164 | LC900 PLATE |
| 463165 | LC1200 PLATE |

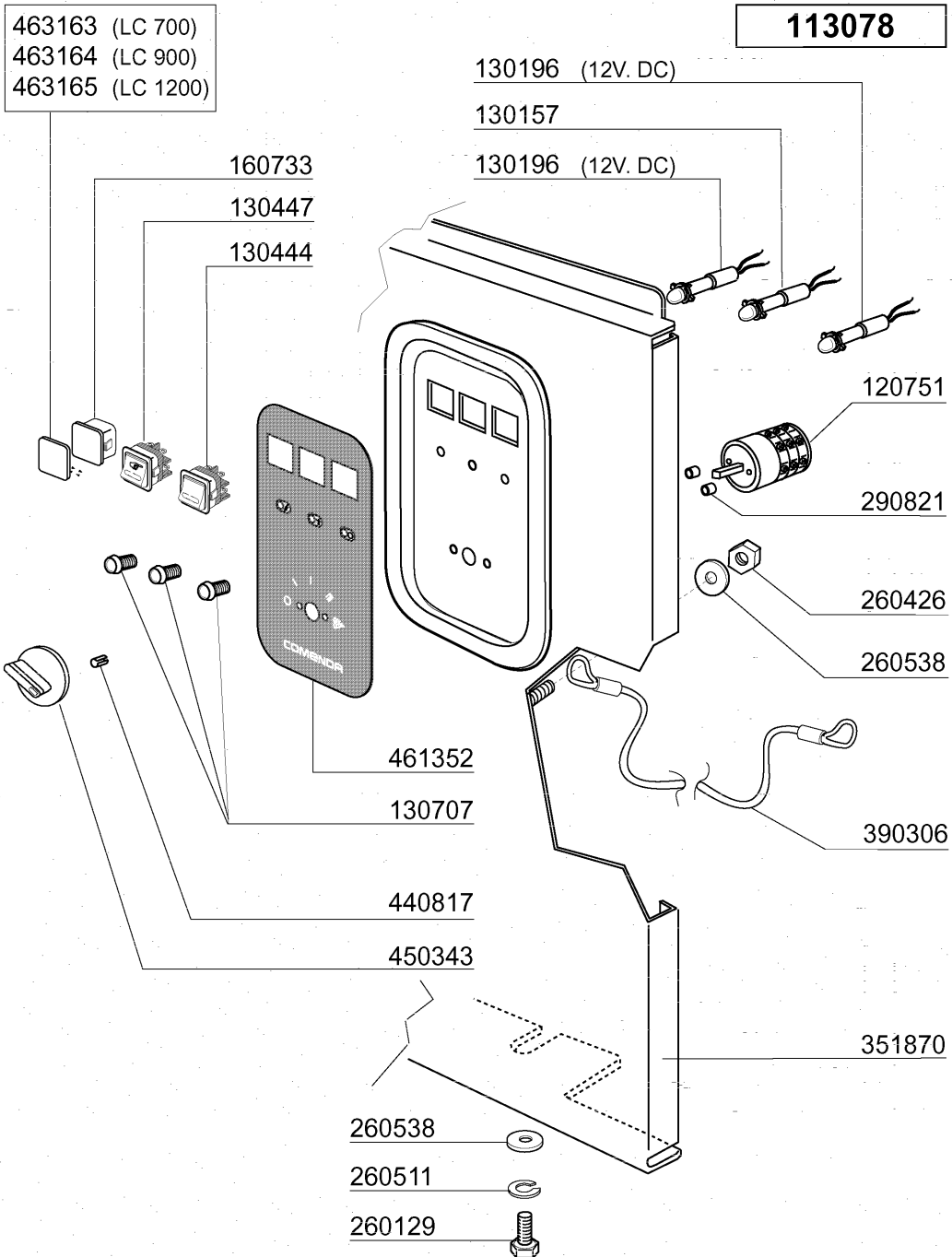

04-2005 | S. AG.

13 - Control panel

| CODE | DESCRIPTION |
|-------------|--------------------------------|
| 113078 | PANN.COM.LC '04 |
| 120751 | 4 POLE SWITCH 16A |
| 130157 | GREEN LED FOR BR-BC-C-SERIES - |
| 130196 | GREEN LAMP |
| 130444 | SWITCH "START CYCLE" F |
| 130447 | CYCLE START SELECTOR FOR C-SER |
| 130707 | TRANSPARENT LENS COVERS (C-SER |
| 160733 | BLANK PLATES |
| 260129 | SCREW TE M 5X20 |
| 260426 | DADI ESAG.CIECHI INOX "M6" |
| 260511 | GROWER WASHER D.5 |
| 260538 | WASHER 18X6X1,5 ST/ST |
| 290821 | DISTANCE PIECE FOR SWITCH |
| 351870 | FRONT PANEL LC2004 |
| 390306 | CABLE |
| 440817 | SNAP RING LSCB/1853/17/00 |
| 450343 | BLUE SWITCH |
| 461352 | LC2004 PLATE |
| 463163 | LC700 PLATE |
| 463164 | LC900 PLATE |
| 463165 | LC1200 PLATE |

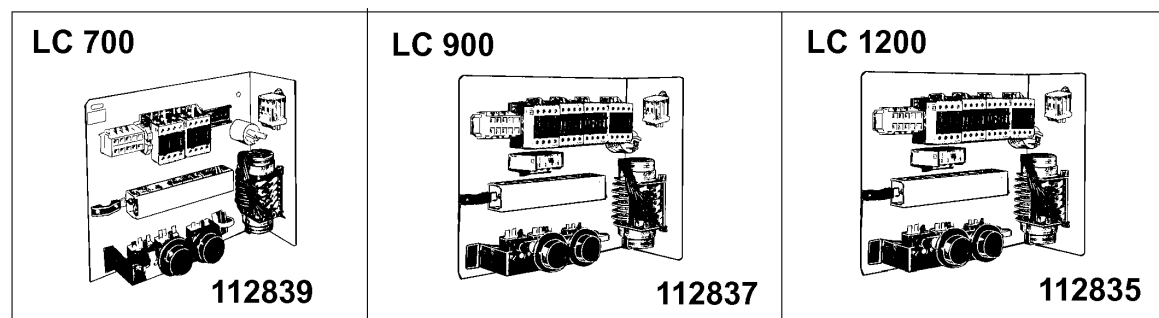
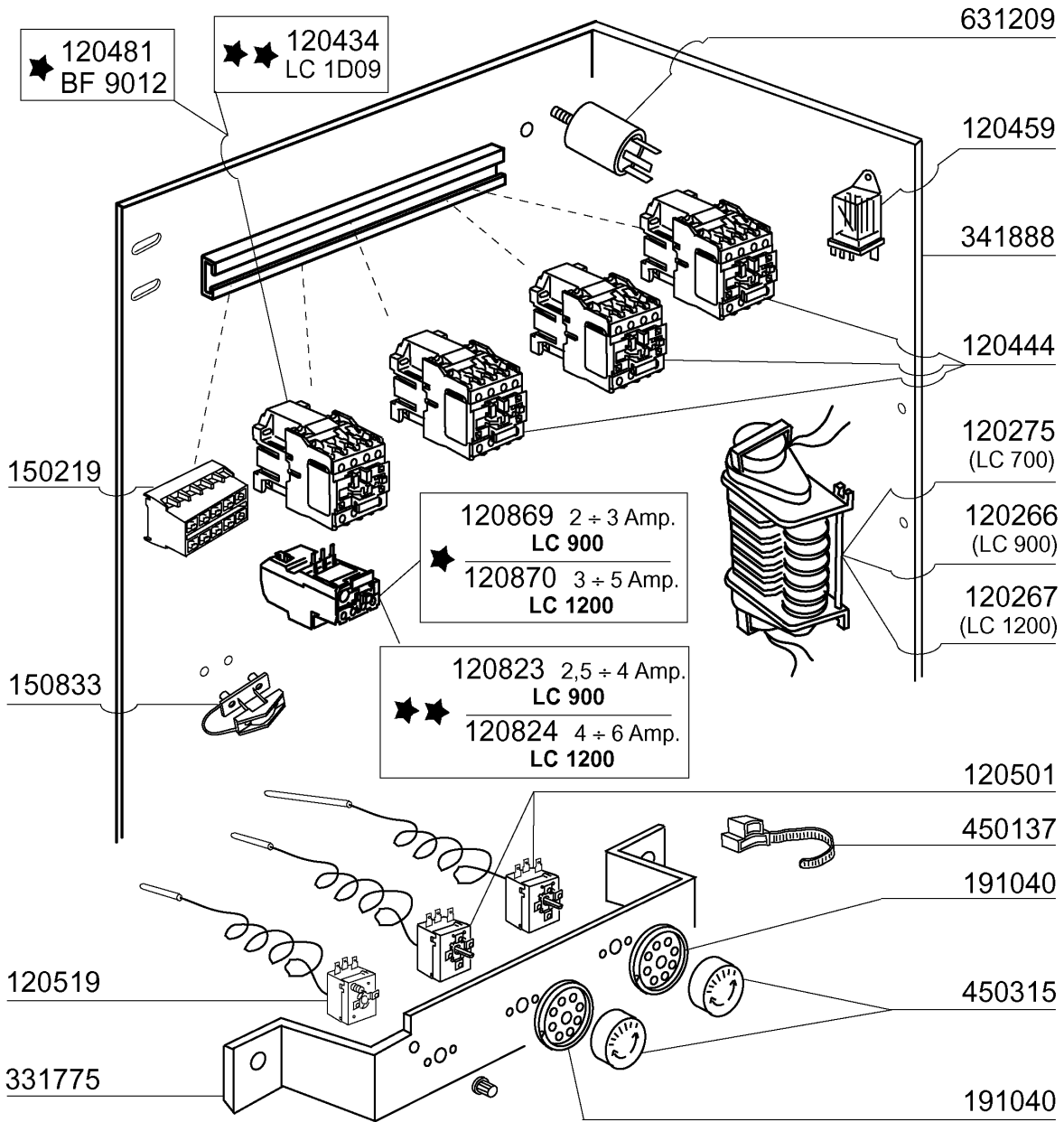

14 - Control box

| CODE | DESCRIPTION |
|-------------|--------------------------------|
| 112835 | WIRING |
| 112837 | WIRING |
| 112839 | WIRING |
| 120266 | TIMER 6 CAMS 75/120/180" |
| 120267 | TIMER 6 CAMS 60/85/120" |
| 120275 | TIMER |
| 120434 | CONTACTOR 9A 220V 50HZ |
| 120444 | CONTACTOR 9A 220V 50HZ |
| 120459 | AUXIL.RELE 16A 220V |
| 120481 | CONTACTOR 9A-230V 50/60HZ |
| 120501 | THERMOSTAT 30/90ØC |
| 120519 | SECURITY THERMOSTAT 95-125Ø |
| 120823 | OVERLOAD RELAY 2.5/4 A |
| 120824 | OVERLOAD RELAY 4/6 A |
| 120869 | OVERLOAD RELAY 2/3,3 |
| 120870 | OVERLOAD RELAY 3/5 |
| 150219 | TERMINAL BLOCK 5P MMQ165VD26 |
| 150833 | CABLE HOLDER BC/BR |
| 191040 | FRAME F.THERMOSTAT KNOB |
| 331775 | BRACKET 3 THERMOSTATS |
| 341888 | CONTROL BOX SUPPORT |
| 450137 | COLLAR CONNECTION WITH BASE 31 |
| 450315 | KNOB F. THERMOSTAT 90Ø |
| 631209 | ANTI-NOISE FILTER |

113080 (LC 700)

113081 (LC 900)

113082 (LC 1200)

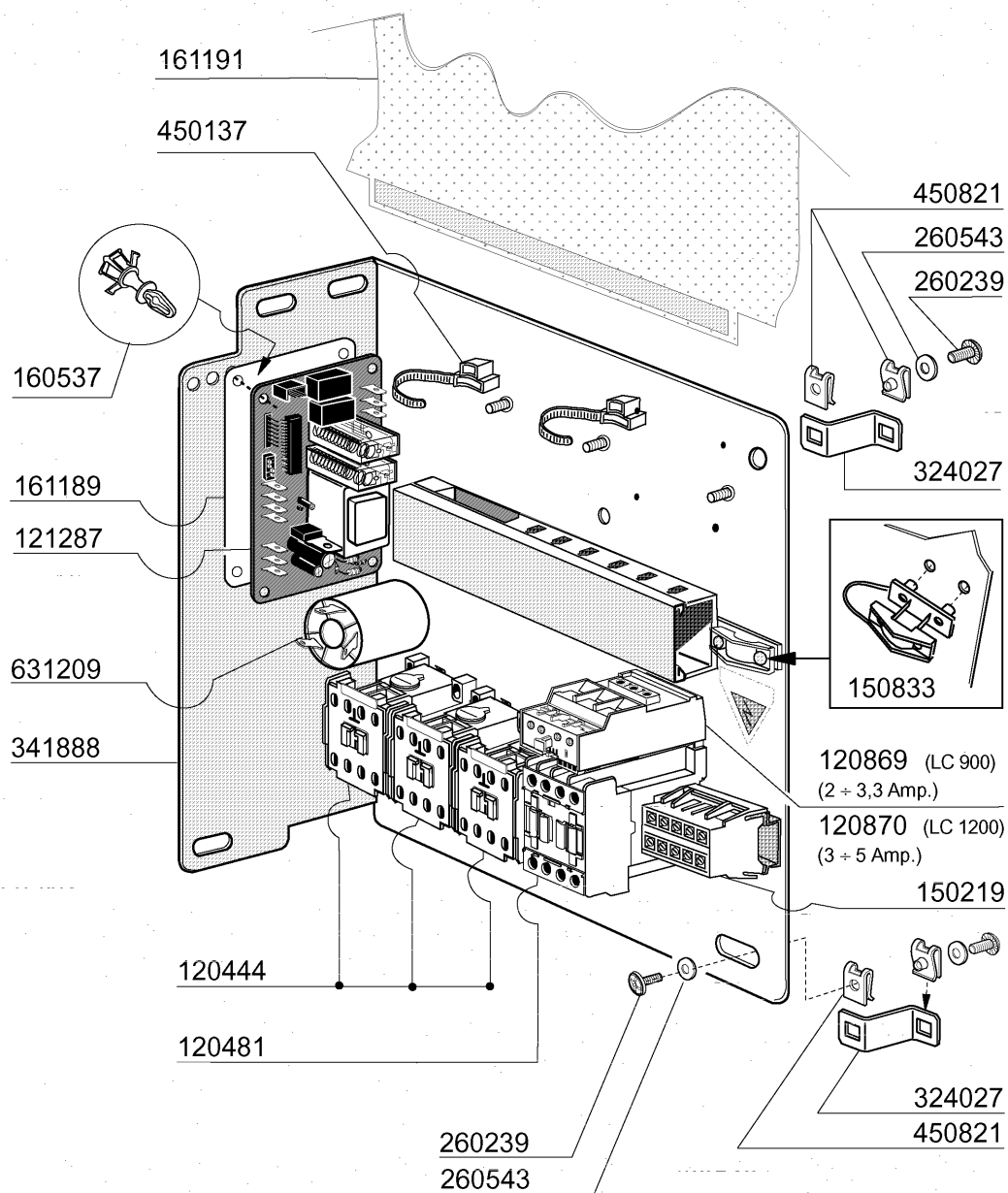

04 - 2005 | S. AG.

15 - Control box

| CODE | DESCRIPTION |
|-------------|--------------------------------|
| 113080 | -IMP.ELET.LC700 '04 (113351) |
| 113081 | IMP.EL.LC900 |
| 113082 | IMP.EL.C1301M 04 |
| 120444 | CONTACTOR 9A 220V 50HZ |
| 120481 | CONTACTOR 9A-230V 50/60HZ |
| 120869 | OVERLOAD RELAY 2/3,3 |
| 120870 | OVERLOAD RELAY 3/5 |
| 121287 | ELECTRONIC TIMER |
| 150219 | TERMINAL BLOCK 5P MMQ165VD26 |
| 150833 | CABLE HOLDER BC/BR |
| 160537 | ELECTRONIC CARD SPACER |
| 161189 | COVER |
| 161191 | CONTROL BOX COVER |
| 260239 | SPECIAL S/S TB-SCREWS M6X20 |
| 260543 | WASHER D.6 ST/ST |
| 324027 | SQUADR.FISS.IMP.EL. LC 2001-08 |
| 341888 | CONTROL BOX SUPPORT |
| 450137 | COLLAR CONNECTION WITH BASE 31 |
| 450821 | SPRING CLIP FASTENER SNU 3634 |
| 631209 | ANTI-NOISE FILTER |

16 - Rinse aid injector

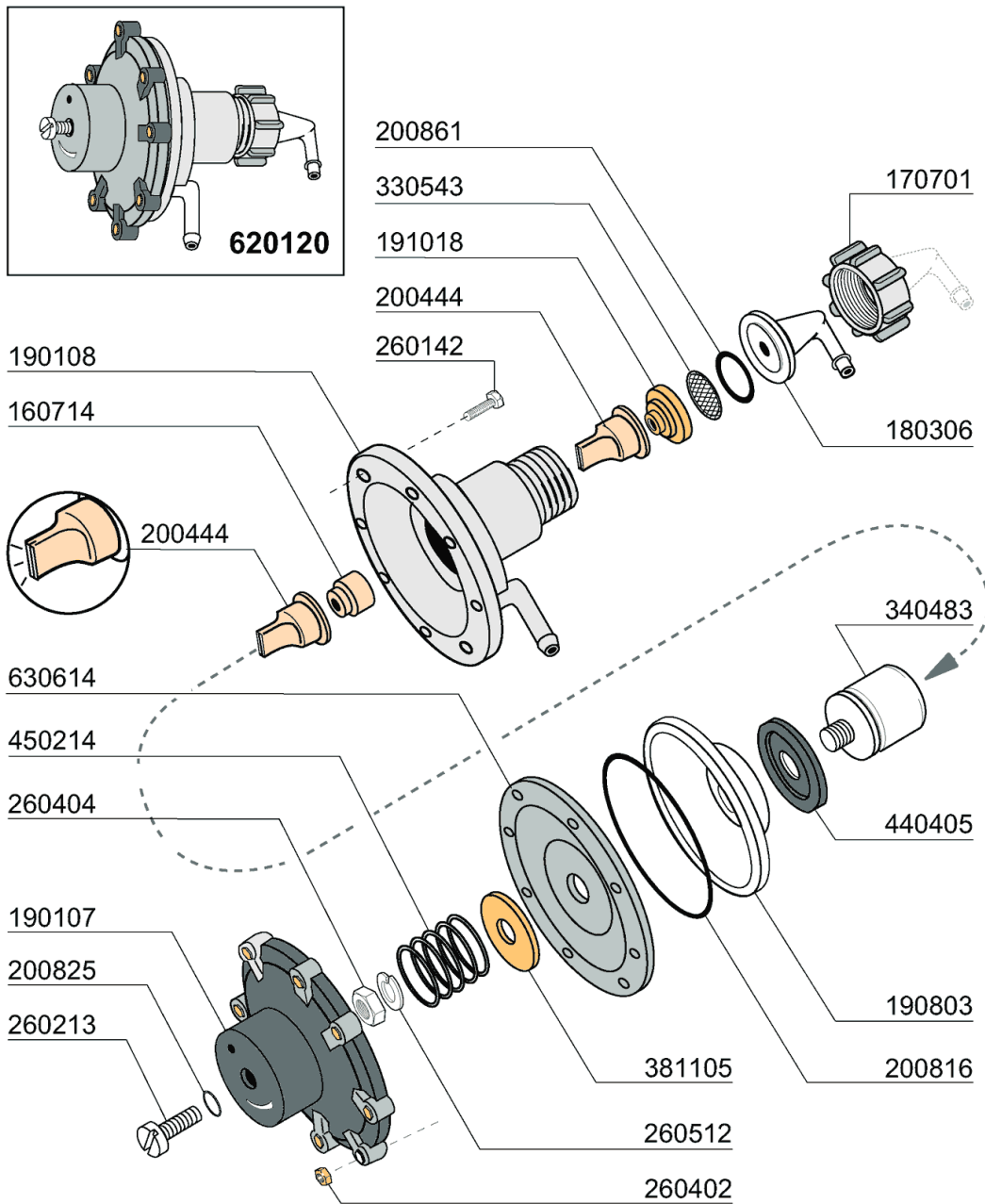

09 - 2007 | S. AG.

16 - Rinse aid injector

| CODE | DESCRIPTION |
|--------|--------------------------------|
| 160714 | PLUG FOR RINSE AID INJECTOR MO |
| 170701 | LOCK NUT 1/2" F.INJECTOR |
| 180306 | NIPPLE F.RINSE AID INJECTOR |
| 190107 | COVER FOR RINSE AID DISPENSER |
| 190108 | VOLUTE FOR RINSE AID DISPENSER |
| 190803 | GASKET SUPPORT RING F.INJECT |
| 191018 | FILTER SUPPORT RINSE AID INJEC |
| 200444 | SUCTION VALVE RINSE INJECTOR |
| 200816 | O-RING 2,5X59,2X64,2 RINSE INJ |
| 200825 | O-RING 3X5X11 RINSE INJECTOR |
| 200861 | O-RING 14X18X2 |
| 260142 | SCREW TE 4X16 |
| 260213 | SCREW TCP 5X25 |
| 260402 | STAINLESS STEEL NUT D4 UNI 55 |
| 260404 | STAINLESS STEEL NUTS D6 UNI 55 |
| 260512 | ST/ST GROWER WASHER D6 |
| 330543 | FILTER RINSE AID INJECTOR D.17 |
| 340483 | PISTON FOR RINSE AID DISPENSER |
| 381105 | DIAPHRAGME DISC |
| 440405 | GASKET FOR RINSE AID INJ. |
| 450214 | SPRING RINSE AID INJECTOR |
| 620120 | RINSE AID INJECTOR |
| 630614 | DIAPHRAGM RINSE INJECTOR |

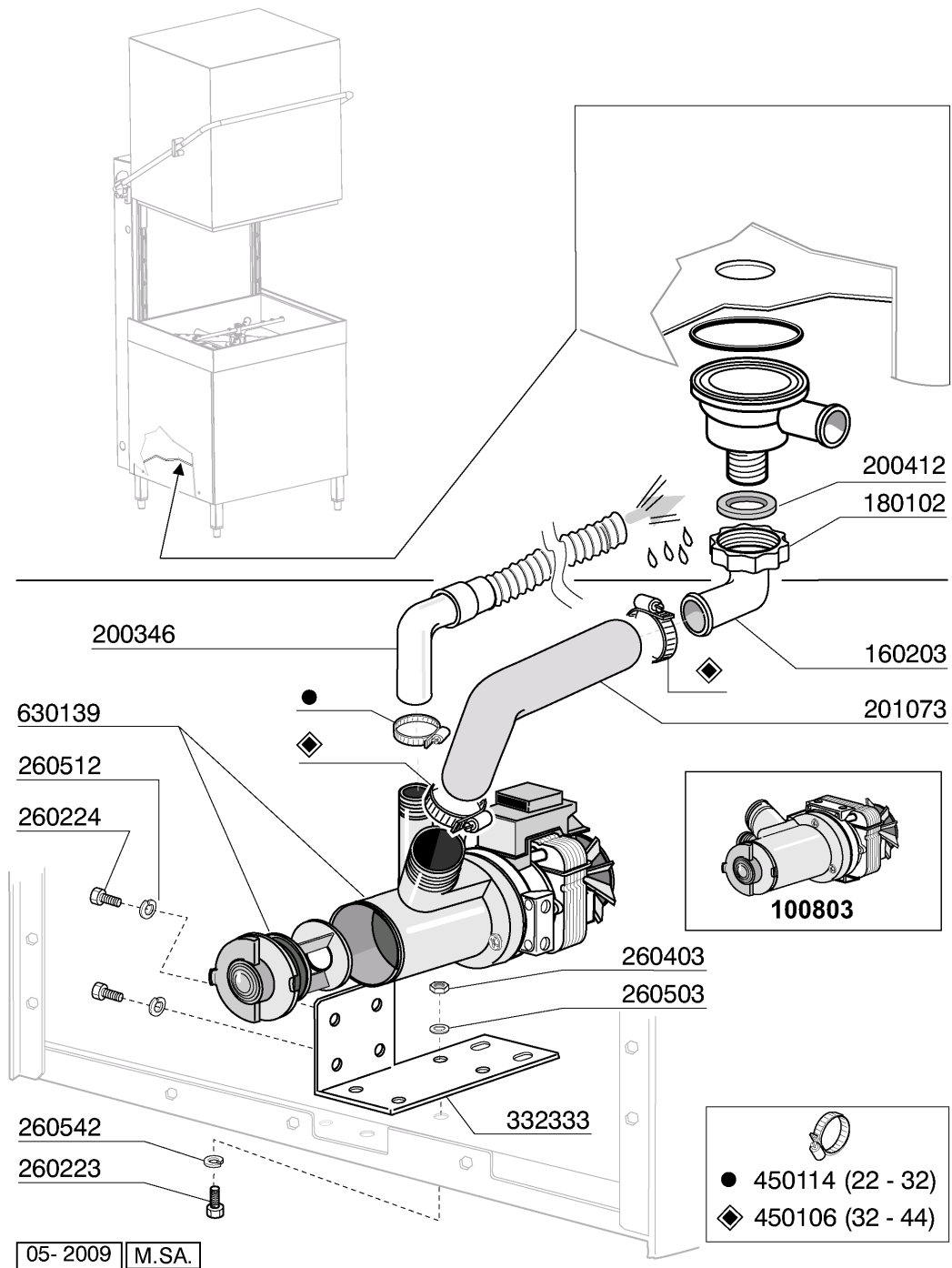

17 - Drain pump

| CODE | DESCRIPTION |
|--------|--------------------------------|
| 100803 | DRAIN PUMP WITH FILTER 220/50 |
| 160203 | ELBOW 1"1/2 N-S-F-C /DRAIN |
| 180102 | DRAIN PIPE NUT 1"1/2 F45-55 |
| 200346 | DRAIN HOSE GLASSWASHER |
| 200412 | GASKET DRAIN 11/2" 45X33X3 |
| 201073 | INLET HOSE LC/CE DRAIN PUMP |
| 260223 | M5X12 MSH/HD SCREW SPECIAL S/S |
| 260224 | TB-SCREW 6X15 B23-10-11-12 |
| 260403 | NUTS D.5 |
| 260503 | STAINL.STEEL FLAT WASHER D5 UN |
| 260512 | ST/ST GROWER WASHER D6 |
| 260542 | WASHER D.5 |
| 332333 | BRACKET FOR DRAIN PUMP |
| 450106 | CLAMP FE ZN 32-44 H=12,2 |
| 450114 | CLAMP FE ZN.22-32 H=12,2 |
| 630139 | DRAIN PUMP VOLUTE WITH FILTER |

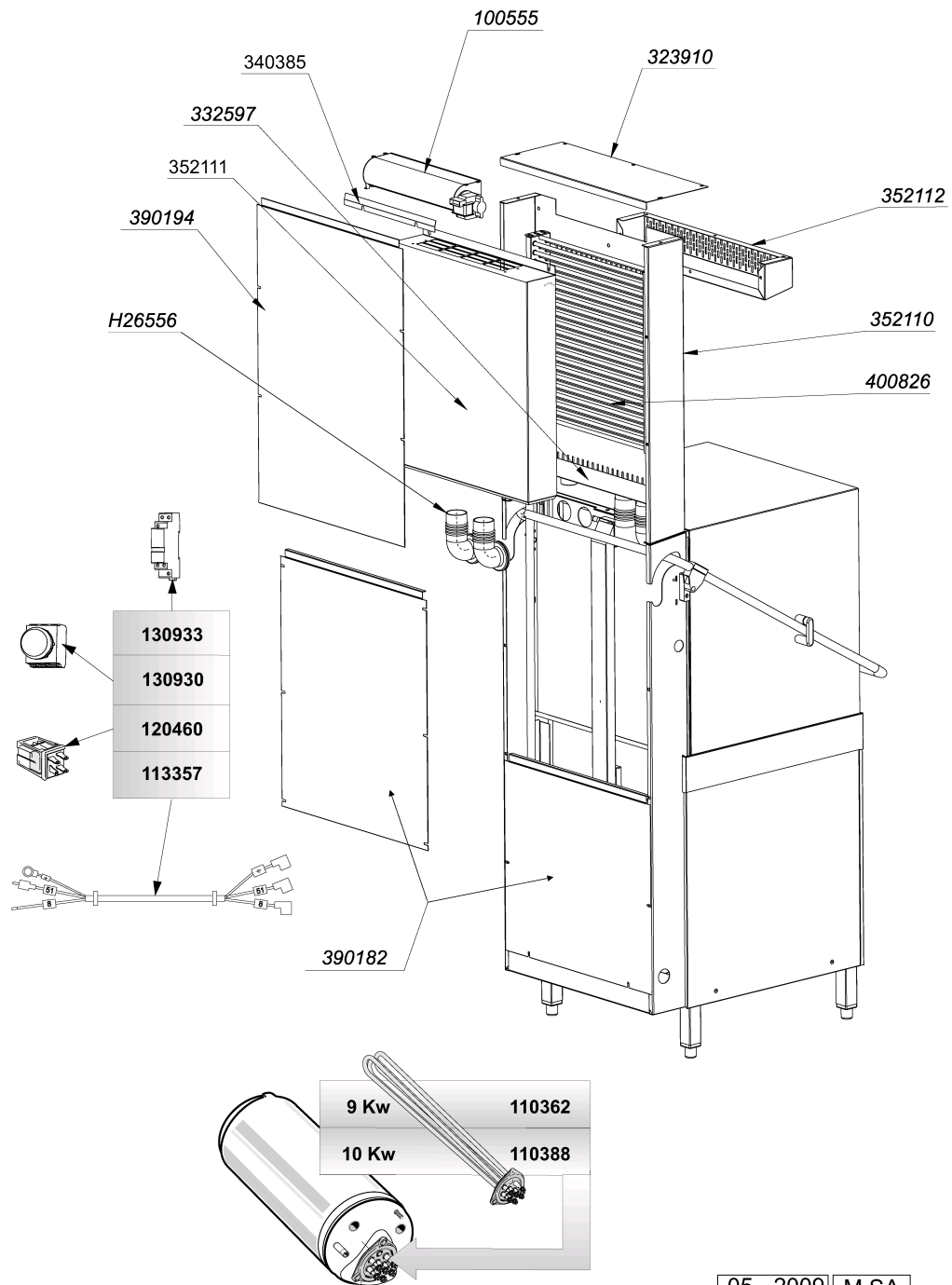

| CODE | DESCRIPTION |
|--------|-------------------------------|
| 100555 | FAN TGA60/1 360-30 |
| 110362 | HEAT.ELEMENT 9000W 220/380V |
| 110388 | HEAT.ELEMENT 10000W 230/400V |
| 113357 | CABLE FOR CRC |
| 120460 | RELAY 16A 220V |
| 130930 | CONTACT ABB 1NO/1NC 180" |
| 130933 | SUPPL. CONTACT NO/NC ABB |
| 323910 | CRC UPPER COVER |
| 332597 | COLLETTORE ASPIRAZ. CRC C2001 |
| 340385 | PARATIA VENT."POST" CRC C2001 |
| 352110 | BACK PANEL |
| 352111 | BACK PANEL CRC |
| 352112 | FRONT COVER CRC |
| 390182 | BACK PANEL |
| 390194 | BACK PANEL CRC |
| 400826 | CRC BATTERY |
| H26556 | HOSE |